



# S&R Energizers

## Family of Vibration Exciters

Buzzes, squeaks and rattles (S&Rs) in vehicles and their components are a major source of customer dissatisfaction, perceived poor quality, complaints in J.D. Power surveys, and warranty claims and costs worldwide.

MB Dynamics is a leader in delivering technology, test processes, and people & services to help OEMs & their suppliers develop and produce vehicles free of squeaks & rattles, with measurable quality. One core S&R technology is the family of MB Energizer Exciters.

### Whisper **QUIET!**

No exciter noise to mask  
S&Rs and frustrate root  
sourcing



Traditional E-D shakers, up to 55 dBA (6-10 sones)

- field coils . . . electrical & audible hum/noise . . . always energized . . . always create heat . . . must be cooled . . . turning blowers OFF is risky
- internal mechanical elements like rolling struts & bearings cause noises

Hydraulic shakers, up to 65 dBA (15-20 sones)

- servo-valve hiss
- oil flow at 3000 psi
- noisy hydraulic power supplies

### MB Energizers 29-30 dBA (1.0-1.2 sones)

- permanent magnets
- no cooling blowers: permanent magnets don't need cooling
- patented flexures: quiet & stiff
- noiseless, friction-less suspension

Recommended in  
GMW 7293TP  
Subsystem &  
Component  
S&R Test Spec

### Bullet-proof Load Support

Radially-stiff, patented flexures support

- payloads with large footprints, and
- unwieldy payloads with offset cg's without damaging the Energizer

Large, integral payload mounting tables

- 200mm dia.
- 250mm dia.

Air spring load re-centering for very heavy payloads

Robust and rugged exciter for durability tests

Virtually no maintenance



PARAMETER	Energizer BLUE	Energizer BLACK	BLACK plus Lever-Arm *
Max. payload, vertical excitation	12kg (25 lbs.)	25kg (55 lbs.)	25kg (55 lbs.)
Max. payload, horizontal	8kg (18 lbs.)	25kg (55 lbs.)	25kg (55 lbs.)
Max. payload with air spring, vertical	30kg (65 lbs.)	90kg (200 lbs.)	25kg (55 lbs.)
Armature plus table or lever-arm wt.	5kg (11 lbs.)	8kg (18 lbs.)	9kg (20 lbs.)
Acceleration, 5 kg payload, uncooled	5.5 g's pk 3.1 g's RMS	8.2 g's pk 4.8 g's RMS	14.9 g's pk 9.0 g's RMS
Acceleration, 15kg payload, uncooled	2.7 g's pk 1.6 g's RMS	4.6 g's pk 2.7 g's RMS	8.7 g's pk 5.2 g's RMS
Acceleration, 30kg payload, uncooled	1.5 g's pk 0.9 g's RMS	2.8 g's pk 1.7 g's RMS	5.4 g's pk 3.2 g's RMS
Accelerations with forced air cooling	2X uncooled	2X uncooled	2X uncooled
Mounting table diameter	200mm (8 ")	250mm (10 ")	250mm (10 ")
Inserts, and bolt-hole pattern	M6 (1/4"-28), 50mm X 50mm	M6 (1/4"-28), 50mm X 50mm	M6 (1/4"-28), 50mm X 50mm
Frequency range	DC – 1,500 Hz	DC – 1,000 Hz	DC – 300 Hz
Suspension driven-axis stiffness	26 kN/m (150 lb/in)	33 kN/m (190 lb/in)	N/A
Suspension transverse-axis stiffness	1000 kN/m (6000 lb/in)	1700 kN/m (9500 lb/in)	N/A
Max. displacement @ test item, pk-to-pk	50mm (2")	50mm (2")	25mm (1")
Max. velocity, pk	1.3m/s (50 in/sec)	1.3m/s (50 in/sec)	1.3m/s (50 in/sec)
Weight incl. sand-filled trunnion base	325kg (715 lbs.)	590 kg (1,300 lbs.)	910 kg (2,000 lbs.)
Footprint	820mm X 640mm (32.37" X 25.25")	980mm X 720mm (38.5" X 28.25")	1110mm X 720mm (43.75" X 28.25")
Height to top of mounting table	640mm (25.18")	810mm (31.75")	890mm (35")
CE Mark	Yes	Yes	Yes
Power requirements	2000 watts, max.	5000 watts, max.	5000 watts, max.
Amplifier input power	208, 220, 240 VAC, 50-60 Hz, single phase		
Amplifier dimensions, all 19" rack mount	430mm X 180mm (17"D X 7"H)	610mm X 460mm (24" X 18" H)	610mm X 460mm (24" X 18" H)
Weight of power amplifier	33kg (73 lbs.)	68kg (150 lbs.)	68kg (150 lbs.)

\* Specs for unit with trunnion base only. Specs for Base Mass + Air Casters available upon request.

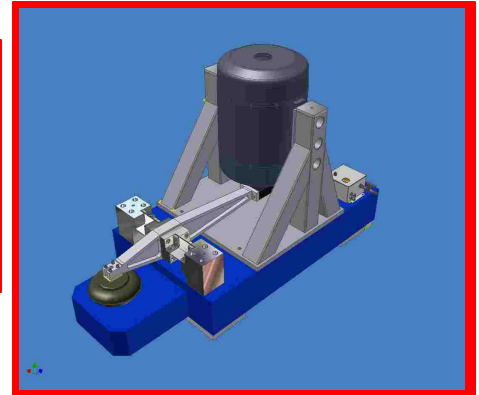
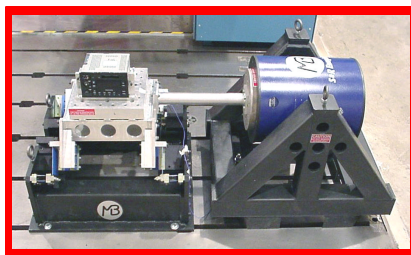

### OPTIONS for Energizer BLUE and BLACK

- Air Spring Load Support for heavy payloads (see Table)
- 2:1 Lever-Arm Integrated on Trunnion Base & Floor Plate, for force doubling
- 2:1 Lever-Arm Integrated on Trunnion Base & Base Mass + Air Casters, for doubling & mobility
- Universal Fixture Kit for testing cockpits, IPs, seats, door modules, sunroofs, etc.
- Quiet Cooling Package (<50 dBA) for durability and S&R aging tests
- Instrumentation Cabinet for mounting amplifiers, controllers, instrumentation, etc.
- Horizontal Moving Table for horizontal vibration, as quiet as BLUEs and BLACKs
- Chamber Readiness Kit to use BLACKs in thermal chambers from -40° C to +80° C